

Double Husk - 100% Full Size

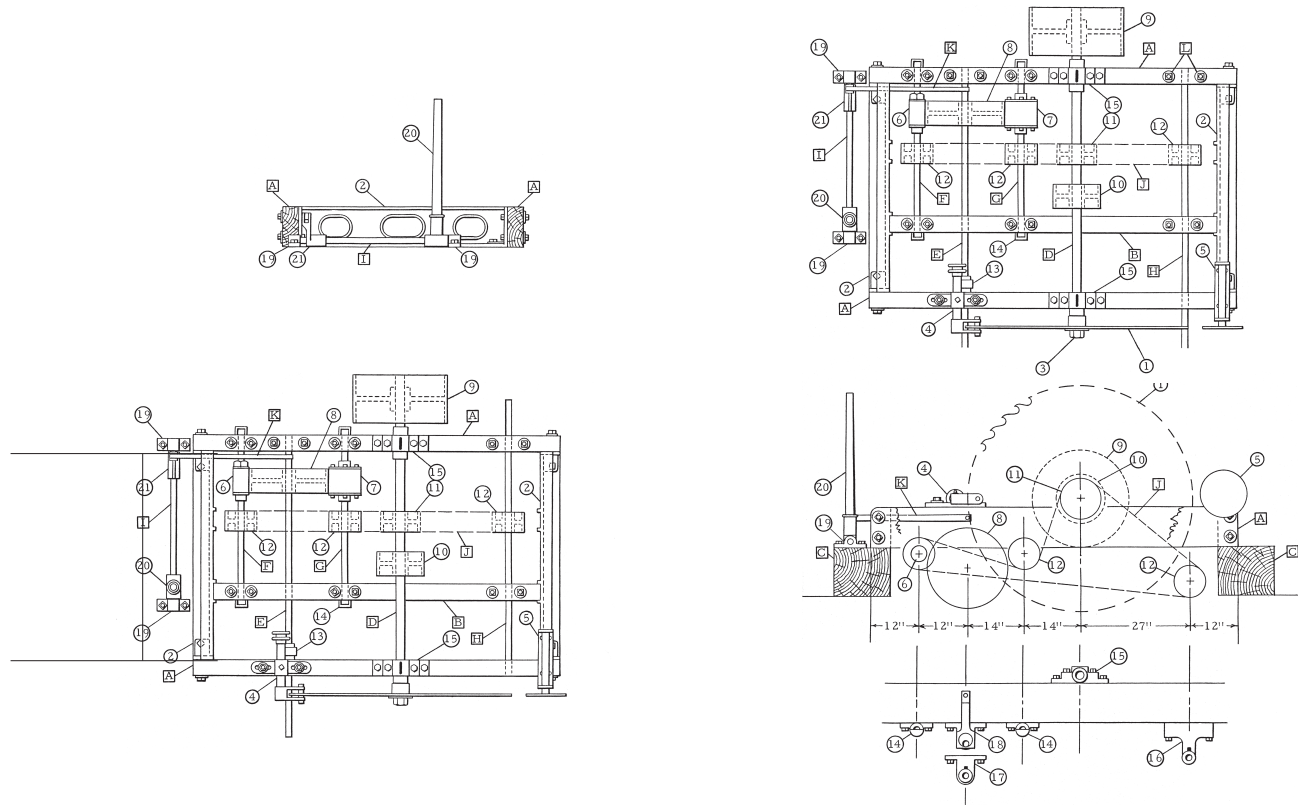

Double Husk - 100% Full Size

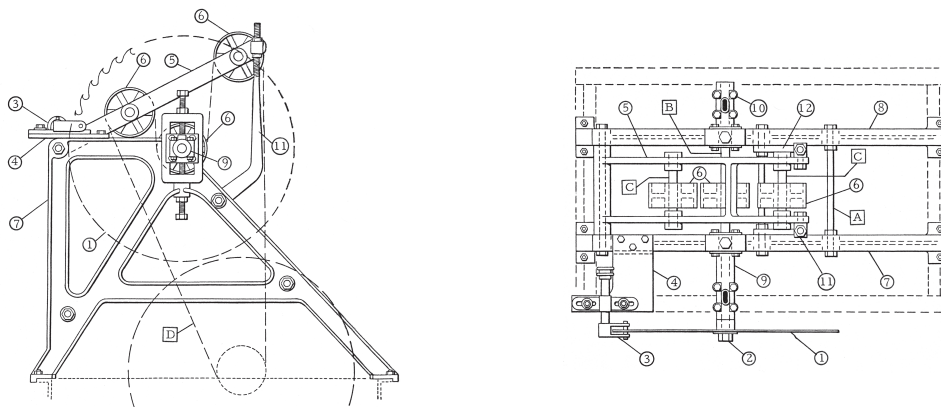

SierraWest™
SINCE 1995

copyright Brett Gallant - No Duplication - for personal use only

Log Carriage Platform

100% Full Size Top View

22' X 46" CARRIAGE (48" GAUGE) WITH SETTERS PLATFORM

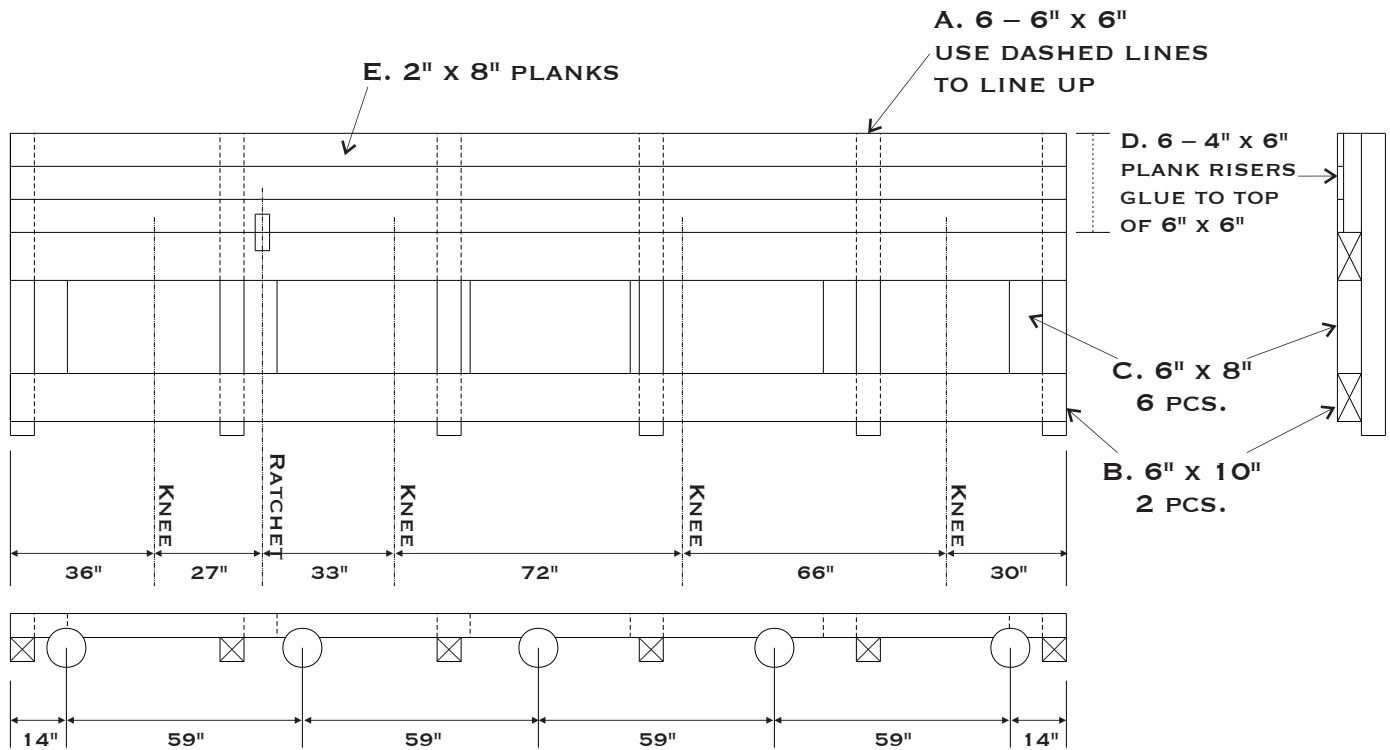

SierraWest™
SINCE 1995

copyright Brett Gallant - No Duplication - for personal use only

Live Rolls

100% Full Size Top View

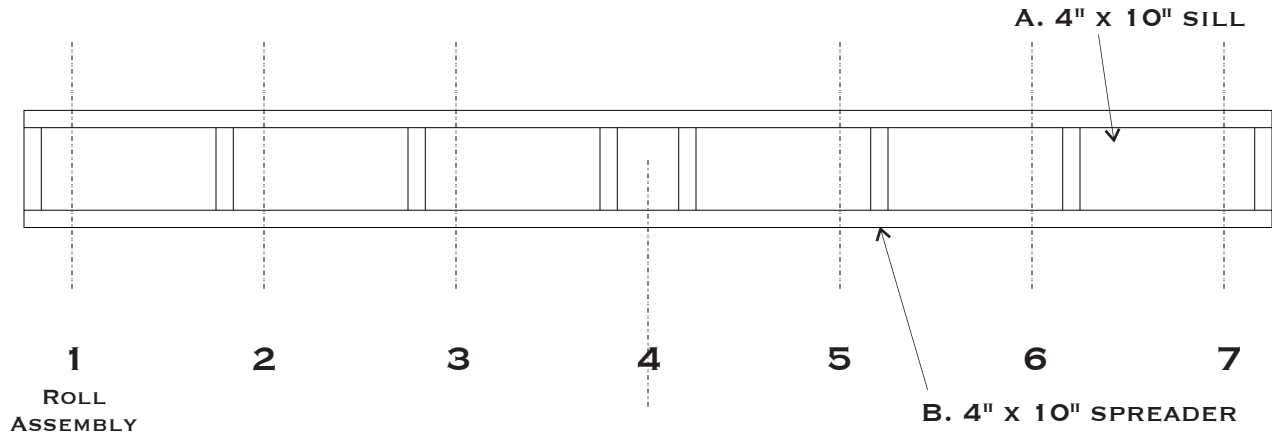

Dead Rolls

100% Full Size Top View

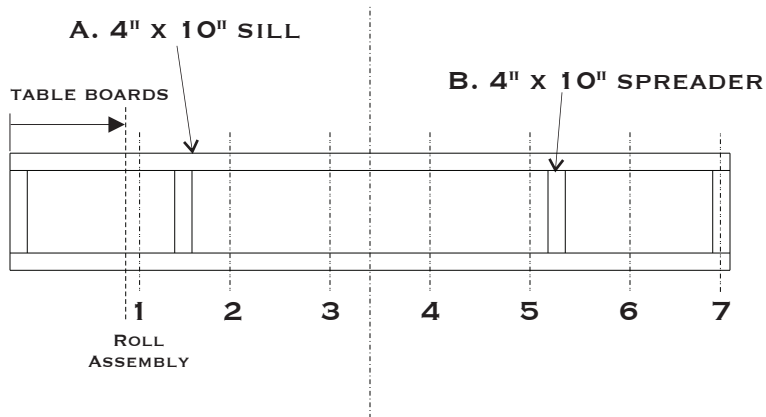

SierraWestTM
SINCE 1995

copyright Brett Gallant - No Duplication - for personal use only

Log Haul Mechanism

100% Full Size Top View

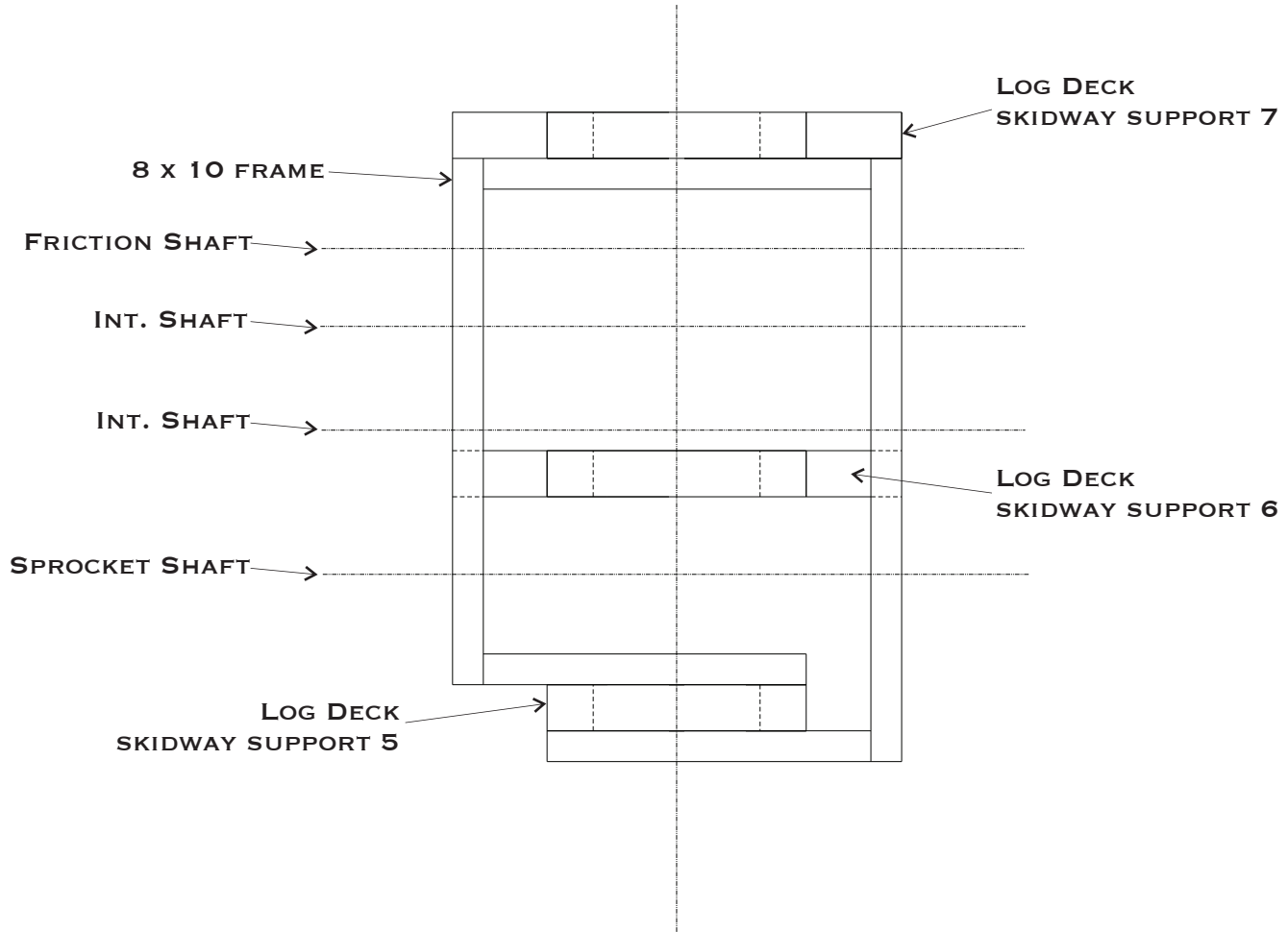

Log Haul Mechanism

100% Full Size Front View

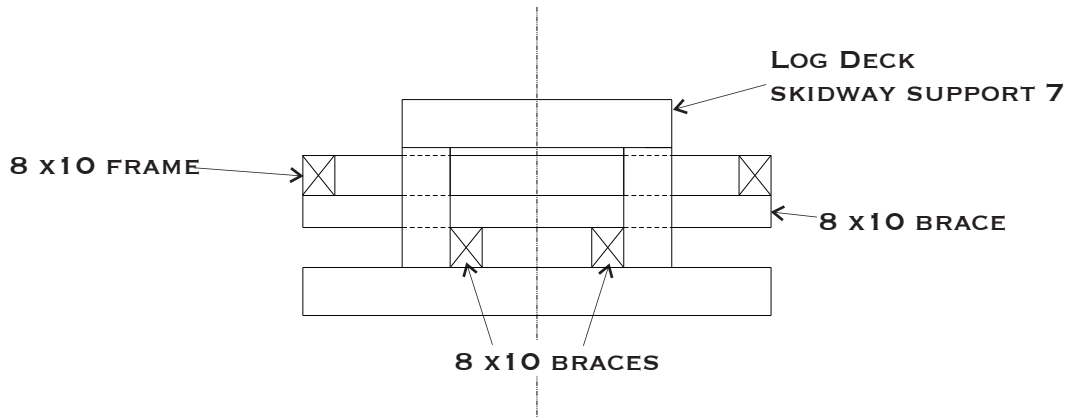

SierraWest™

SINCE 1995

copyright Brett Gallant - No Duplication - for personal use only

Edger Feed Table

100% Full Size Top View

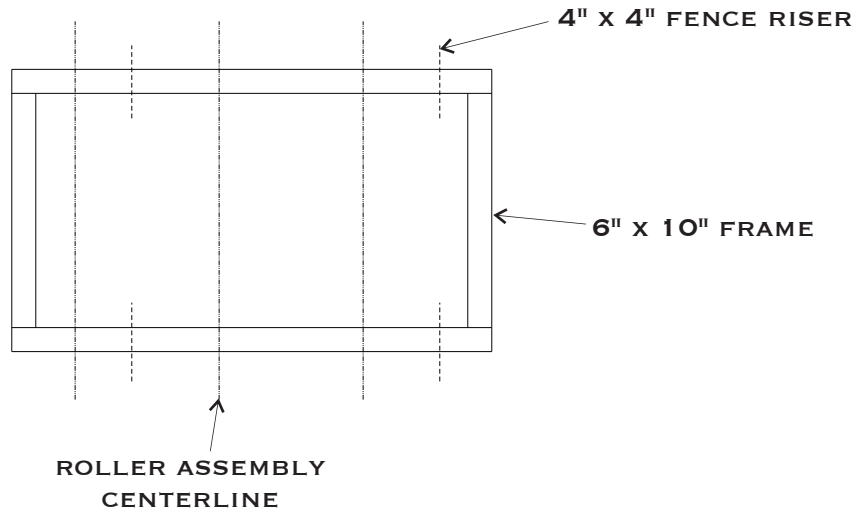

Edger Discharge Table

100% Full Size Top View

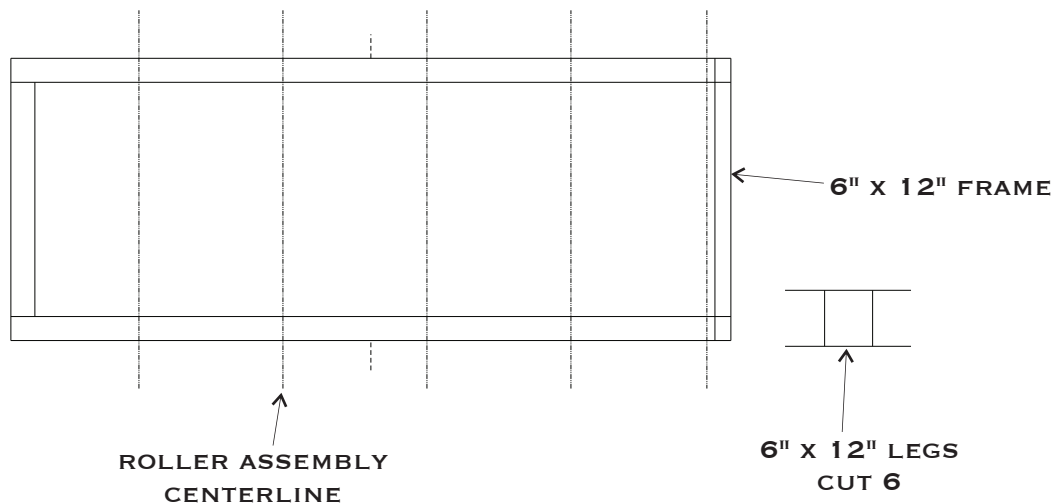

SierraWest™

SINCE 1995

copyright Brett Gallant - No Duplication - for personal use only

Machinery Layout

Close to Scale

Use the actual completed pieces of machinery to arrange and plan the floor of your mill. The optional line shaft kit includes additional information on setting the drive shafts and locating the optional horizontal boiler and mill engine.

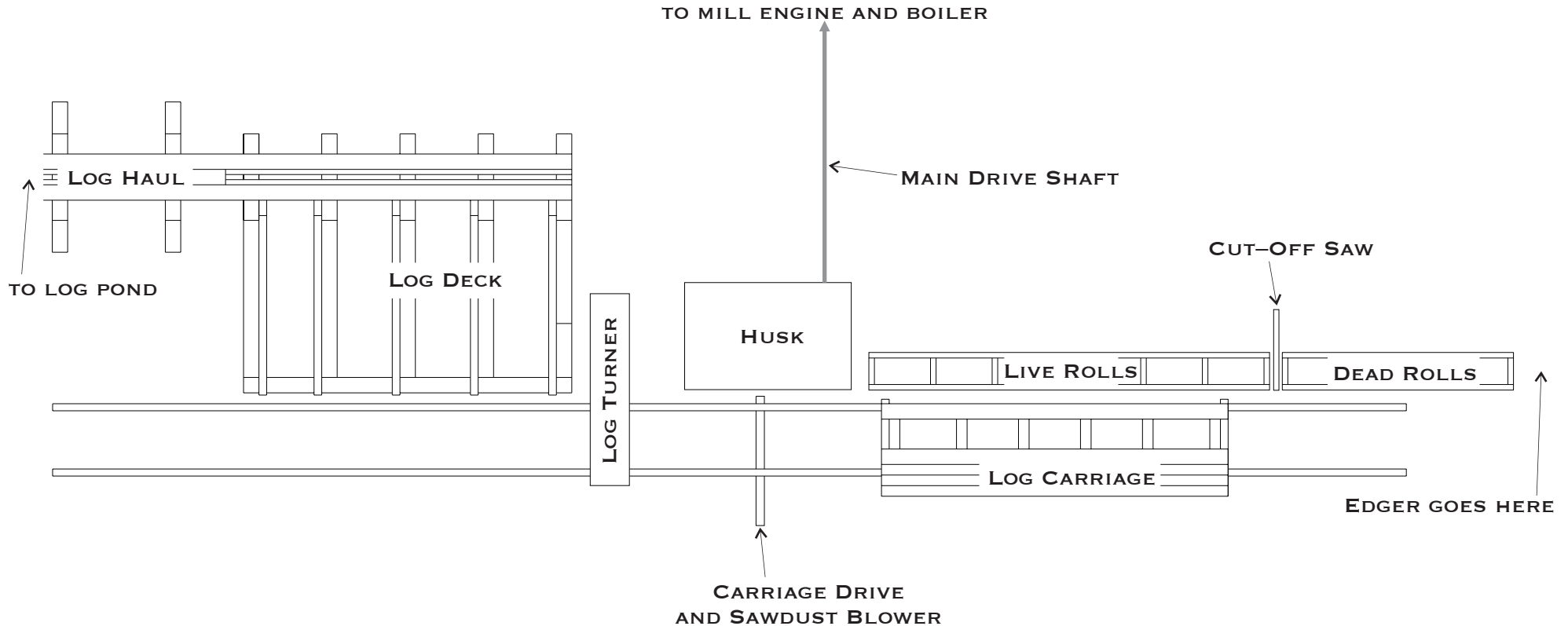

SierraWest™

SINCE 1995

copyright Brett Gallant - No Duplication - for personal use only

Log Deck

100% Full Size Side View

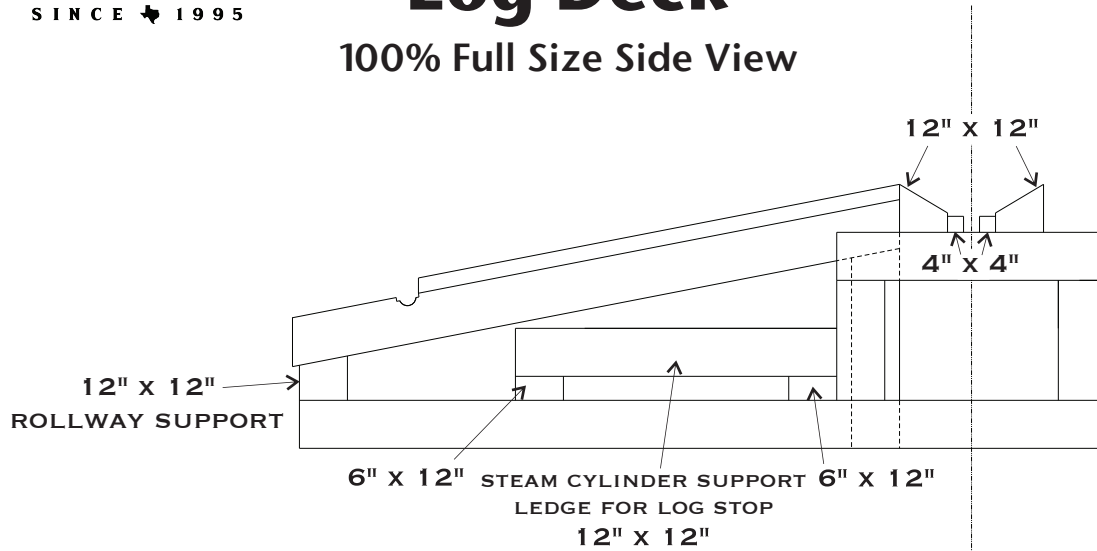

Log Deck Skidway Support

100% Full Size Side View

Make 5 identical for supports 1 - 5



Log Deck Rollway Support

100% Full Size Side View

Make 5 (notch 3)

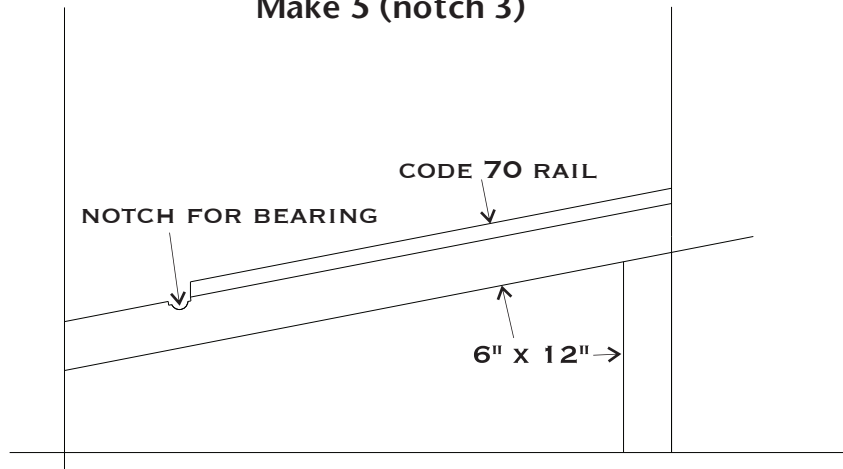

Log Deck Skidway Support

100% Full Size Side View

Make 2 identical for supports 6 and 7

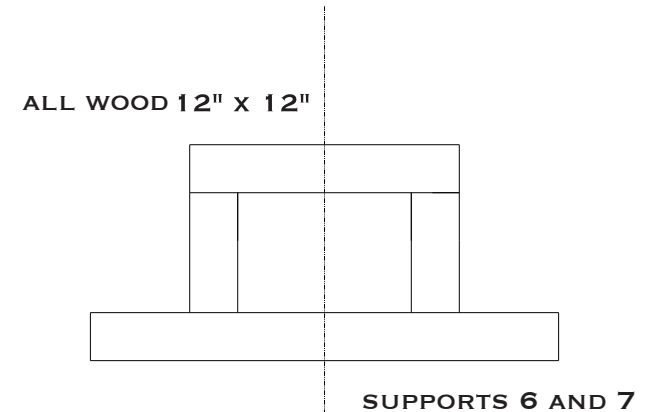

Log Deck

100% Full Size Top View

SierraWest™
SINCE  1995

