

## WP-900 Single Blade Circular Husk

### WP-900 Parts Provided:

- |   |   |
|---|---|
| <ol style="list-style-type: none"> <li>1. Blade</li> <li>2. End Casting (2)</li> <li>3. Blade Hub</li> <li>4. Blade Guide</li> <li>5. Slitter</li> <li>6. 4" Paper Friction</li> <li>7. 8" Paper Friction</li> <li>8. 20" Iron Friction</li> <li>9. 12" x 24" Drive Wheel</li> <li>10. 6" x 12" Drive Wheel (for second blade)</li> <li>11. 5" x 10" Wheel</li> </ol> | <ol style="list-style-type: none"> <li>12. 5" x 8" Wheel (3)</li> <li>13. 1½" shaft Coupling</li> <li>14. Feed and Reverse Shaft Pillow Block (4)</li> <li>15. Blade Arbor Pillow Block (2)</li> <li>16. Idler/Blower Shaft Pillow Block (2)</li> <li>17. R.H. Carriage Drive Shaft Pillow Block</li> <li>18. L.H. Carriage Drive Shaft Pillow Block</li> <li>19. Actuating Shaft Pillow Block (2)</li> <li>20. Actuating Lever</li> <li>21. Actuating Arm</li> </ol> |
|---|---|

### Additional Items Needed:

- |                         |                                    |
|-------------------------|------------------------------------|
| A. Outside Sill (2)     | 4" x 10" x 92" Stripwood           |
| B. Inside Sill          | 4" x 10" x 82" Stripwood           |
| C. End Timber (2)       | 12" x 14" x 60" Stripwood          |
| D. Blade Arbor          | .045" Brass Wire                   |
| E. Carriage Drive Shaft | .032" Brass Wire                   |
| F. Feed Shaft           | .032" Brass Wire                   |
| G. Reverse Shaft        | .032" Brass Wire                   |
| H. Idler/Blower Shaft   | .032" Brass Wire                   |
| I. Actuating Shaft      | .032" Brass Wire                   |
| J. 6" Belt              | "Tyvek" Envelope                   |
| K. Actuating Link       | .010 x .030 Brass or Styrene Strip |
| L. Nut/Bolt/Washer      | Grandtline 93                      |

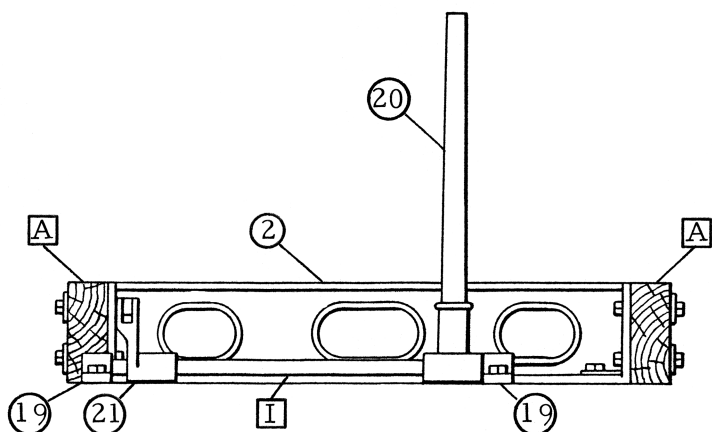
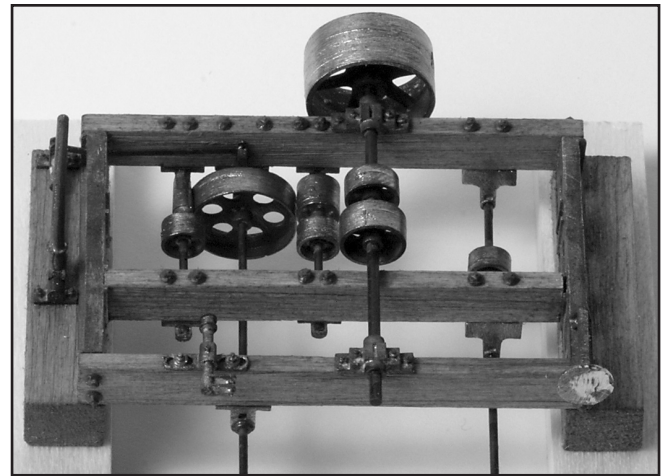

©2003 SierraWest Scale Models  
 Original C.H.B. Models drawings by Charles H. Brommer.  
 Supplemental templates by Brett Gallant.



P.O. Box 250088  
 Plano, Texas 75025  
 972-618-5563  
[sierrawestscalemodels.com](http://sierrawestscalemodels.com)

WP-900 Single Blade Circular Husk

